

# Technical Manual

KITCHEN COUNTERTOPS



NEOLITH





04	01. PRODUCT
08	02. HANDLING AND STORAGE
16	03. INSPECTION
20	04. CUTTING RECOMMENDATIONS
28	05. DESIGN AND FABRICATION
46	06. HEAT
50	07. GLUE
54	08. PROTECTIVE EDGES & PROFILES

*Due to the uniqueness of the materials used in North America to produce kitchen countertops, a specific countertop manual was created for this market which is only applicable in the USA and Canada. The "Technical Kitchen Countertop Manual" should be used in all other countries of the world.*

*Each marble producer must follow the manual that corresponds to their market in order to ensure proper production pursuant to the typical local materials.*

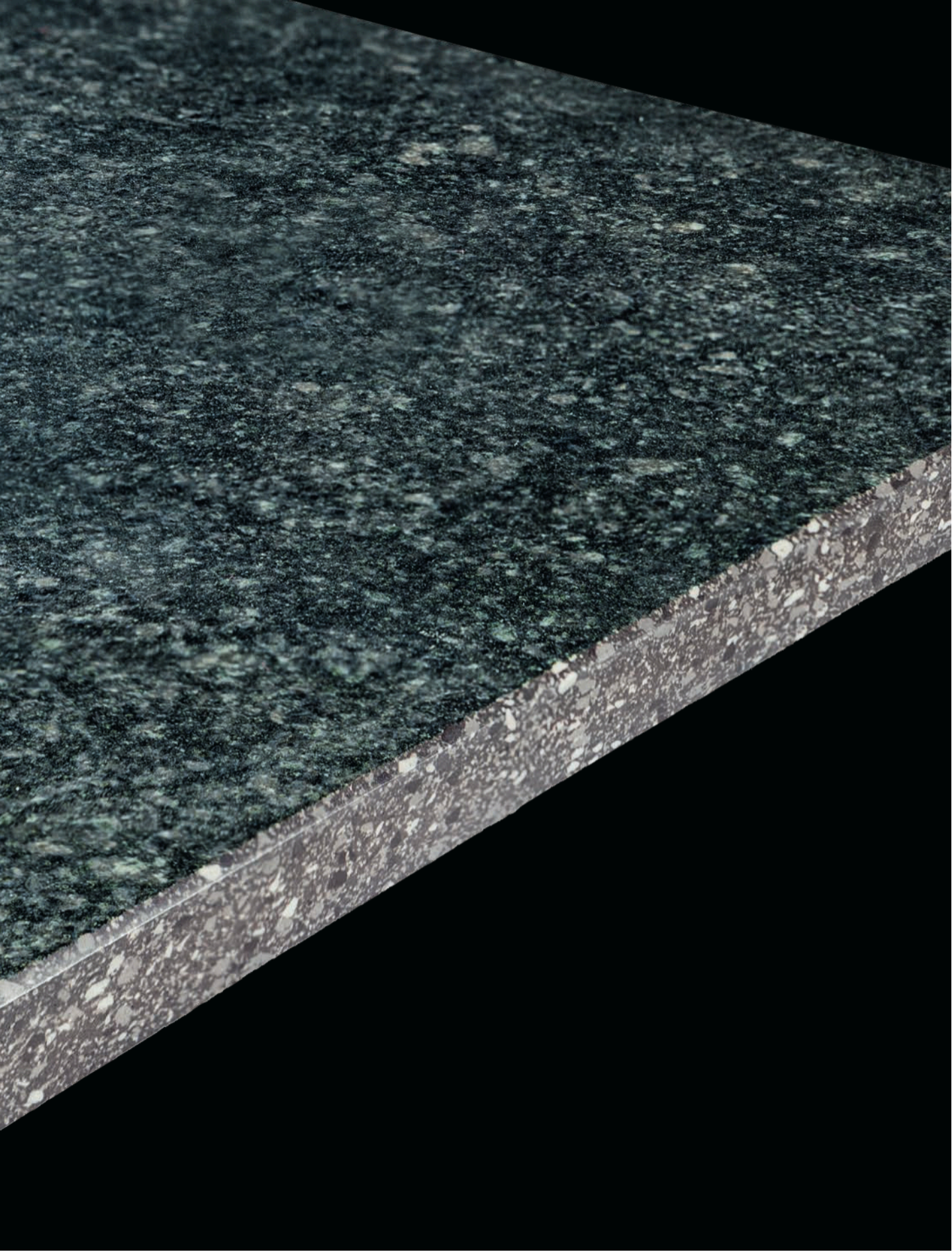

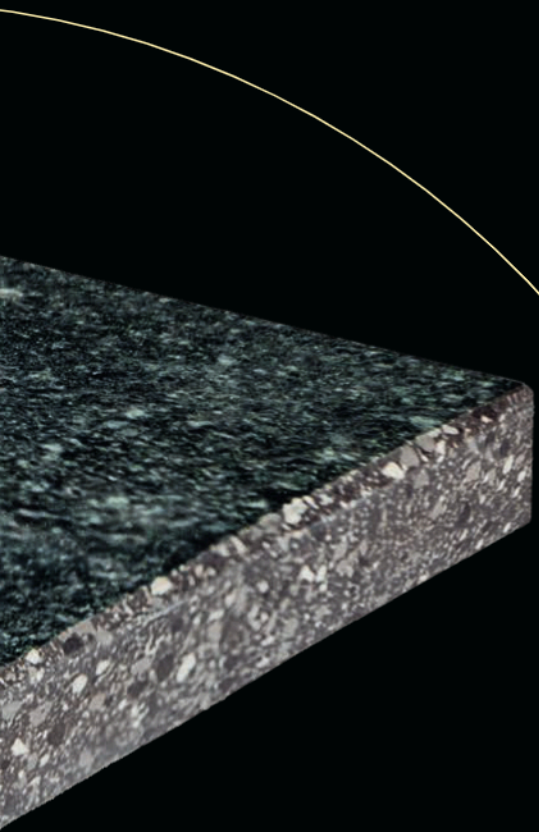

01/  
Product

# 01/ Product

## 1.1 FORMATS

Neolith offers Premium sintered stone surfaces in four different thicknesses. Each one has its own specific range of applications:

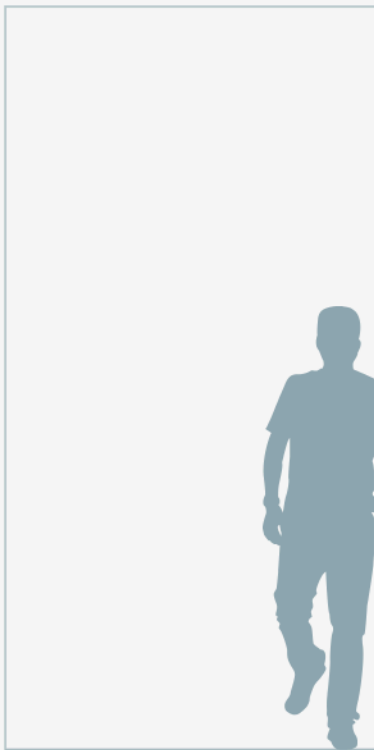

**3.200x1.600 mm**  
126"x64"

**12 mm - 1/2"**

kitchen worktops, bathroom vanities, table tops

**20 mm - 3/4"**

kitchen worktops, table tops

*The measures above are net measures. Please note that unless it is specified in the order, the slabs will be delivered in gross measure (eg: 3.250x1.550mm instead of 3.200x1.500mm) in order to protect the usable size of the board from possible damage caused during transport.*

# 01/ Product

## 1.2 THICKNESSES

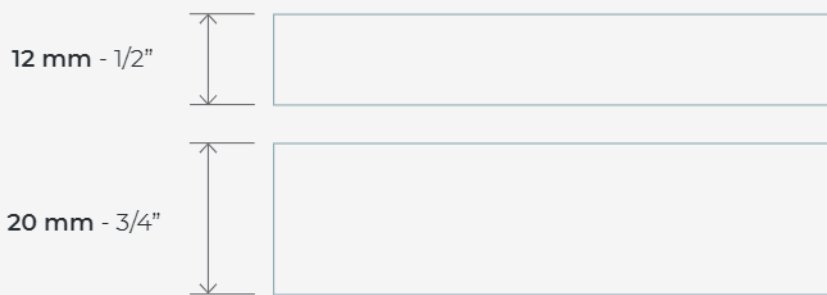

## 1.3 TECHNICAL CHARACTERISTICS OF THE PRODUCT



See the technical data  
sheet at [neolith.com](https://neolith.com)



# 02 Handling and storage

## 02/ Handling and storage

Neolith slabs must be loaded, unloaded and transported by means of a forklift, bridge crane or other hoisting device.

Whenever handling and transporting, the slabs must be balanced taking their center of gravity into account.

The following table summarizes the weight per slab and per square meter:

Thicknesses (mm)	12	20
Weight (kg/m <sup>2</sup> )	29	48

It is recommended that Neolith be handled by trained and qualified personnel.

### 2.1 TRANSPORTING WITH A CLAMP

Neolith recommends using the following type of clamp for lifting and moving individual slabs:

Neolith Slab  
handled with  
a clamp

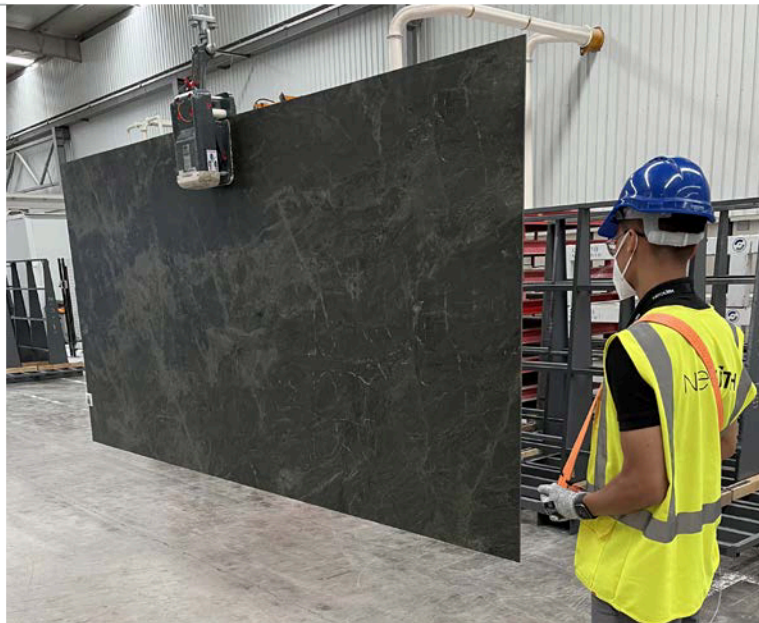

## 2.1 TRANSPORTING WITH A CLAMP

Always pay attention to the movement and handling of the slabs to prevent splintering or breakage.

The additional width of the recommended clamp will prevent the slab from bending during handling to, thus, prevent undesirable breakage.

Contact Neolith for more details.

### RECOMMENDATIONS:

Clamping more than 1 slabs at the same time is not recommended.

## 2.2 TRANSPORTING WITH SLINGS

Using canvas slings to move several slabs at the same time is recommended.

Metal slings must not be used to handle Neolith slabs.



**Make sure to cover all metal surfaces that may come into contact with the slab with adhesive foam tape.**

## 2.3 MANUALLY TRANSPORTING A NEOLITH SLAB

Follow the handling safety recommendations to avoid material breakage during handling.

Moving a Neolith countertop

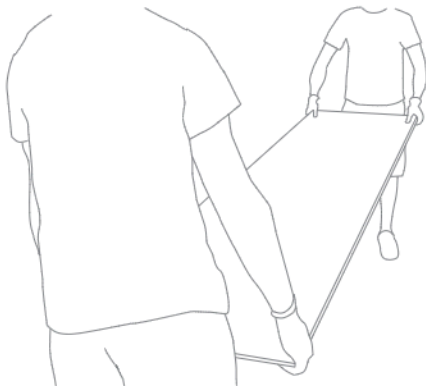
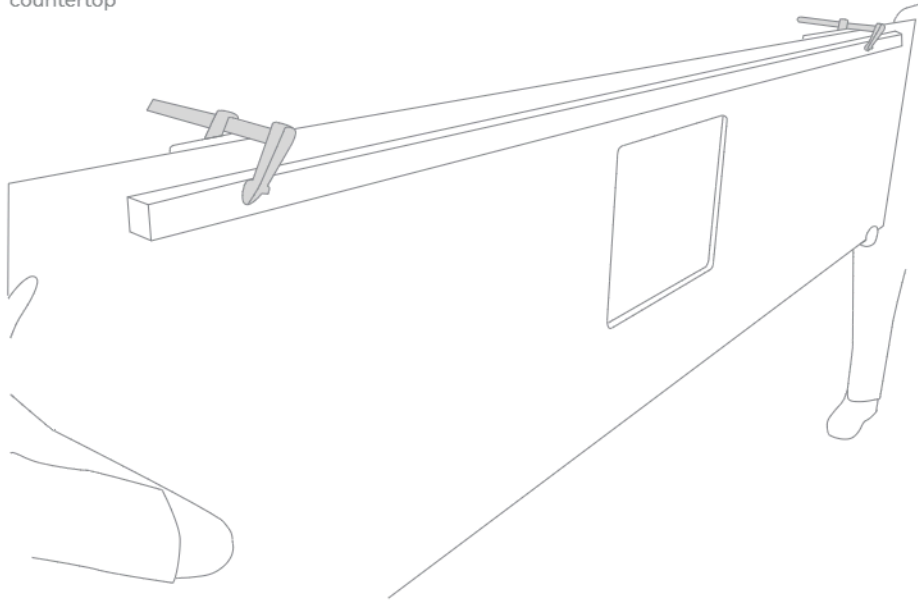

Incorrect

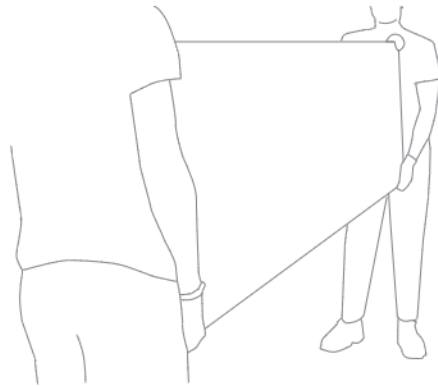

Correct

Raising a Neolith countertop onto a bench



Incorrect

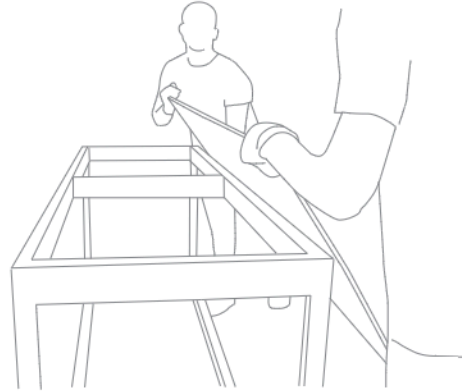

Correct

## 2.4 TRANSPORTATION AND STORAGE OF SLABS

When slabs are transported on the A-frame, they shall always be secured with at least two straps of the sling or webbing type.

When it is necessary to remove the strapping from the A-frame or packages, this shall be done immediately prior to the work to be carried out.

Before removing the strapping from the A-frame, the use of one of two restraint systems is mandatory: safety poles (U-type structure) or upper restraints (inverted U-type stops for the upper part of the A-frame or similar) that guarantee that, in the event of slabs coming loose from the A-frame, they do not fall on the workers.

U-type safety retainer.



Upper retainers (inverted U type).



Keep in mind that trestles and slabs have very high weights, therefore, whenever they are going to fall, NEVER try to stop them. Never stand in the line of fire of a falling heavy object.

When transporting with an overhead crane, keep a safe distance from the loads being transported, foreseeing that the A-frame or slabs themselves may fall.

If loads must be guided, use ropes or similar.

In A-frame storage areas, aisles 1 meter wide should be left between the rows of A-frame.

Broken parts can have very sharp edges. Whenever handling or processing a slab, wear gloves and cut-resistant sleeves, as well as protective goggles.

Neolith recommends storing slabs using either A-frames or storage racks. Its further recommended to secure stored slabs with ratchet straps when storing slabs on A-frames.

Place the slabs length-wise on sufficiently protected beams to prevent the slabs from splintering.

When using A-frames to support Neolith, 3mm and 6mm slabs need at least three support points, distributed evenly along the back of the slab; a full support is recommended - an unused granite or marble slab with sufficient width, for example.

**Avoid positioning large slabs against smaller slabs:**

---

Storage of Neolith slabs in the shop



The supports must be able to hold the entire surface of the part during transport. Supports that are too small may cause the part to break:

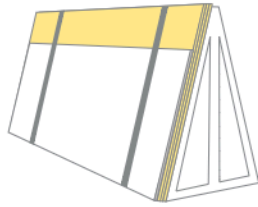

Correct

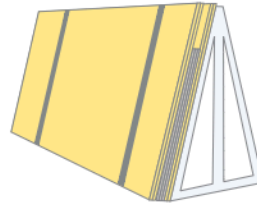

Incorrect

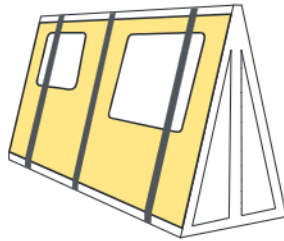

Correct

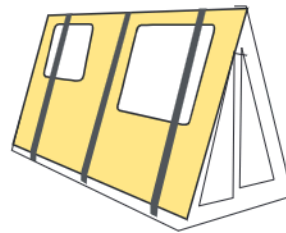

Incorrect

Regardless of the storage method, we advise not setting other materials on top of Neolith slabs, especially on polished finishes. If it is necessary to place something on the slab, separate the materials with appropriate spacers

---

## 2.5 TRANSPORT BY ROAD

When transporting Neolith slabs/pieces, ensure the material is fully supported and secured using straps/belts to prevent damage during transport. Ensure the weight of the load is evenly distributed during the loading and transport of the material.

For more information, please see  
**Neolith Transport&Storage Manual**

# 03 Inspection



## 03/ Inspection

Neolith recommends deep-cleaning the slab and doing a meticulous visual inspection to check whether the slab complies with the quality requirements. Check for the following when carrying out the visual inspection.

- Fissures/Cracks
- Stains
- Slab to slab colour/tonality match
- Thickness
- Shine variations
- Flatness/Warpage
- Surface contamination
- Pinholes or blisters
- Imperfections

This should be the first step prior to starting production. Doing the inspection in a well lit area to identify possible imperfections not seen when flat is recommended.

\*No claims will be accepted for installed or manufactured material when defects were already present upon delivery of the material. Stone masons are responsible for determining whether the slabs are adequate for use. If it is determined that the material is not of suitable quality, they should be exchanged before the slabs are cut or modified in any way.

### 3.1 SLAB CHARACTERISTICS

#### 3.1.1 Flatness/Warpage

To check the flatness of a slab, it should be positioned horizontally on a completely flat base. The flatness is measured by placing an aluminum rod or similar object on the surface of the slab, covering the entire width or length of the slab.

Determining warpage or flatness of an upright/vertical slab is not recommended.

Image 9: Set-up for correct measurement of the warp.



MAXIMUM TOLERANCE IN THE SLAB WIDTH: 2 mm  
 MAXIMUM TOLERANCE IN THE SLAB LENGTH: 4 mm

### 3.1.2 Tone

Neolith is constantly working so the tone of the current batches match the tone of previous batches. Despite our efforts, slight variations in tone may occur between different batches of the same model due to the use of natural raw materials.

Deviations in tone are more noticeable among the various thicknesses of a single model given the way in which each thickness is produced.

Before cutting, visually inspect the slabs to ensure the tone of the different slabs is acceptable. Do this inspection under lighting conditions that are similar to what would be found at the place of installation. We recommend not combining slabs from different batches.

### 3.2 SLAB IDENTIFICATION

Each slab has a label with important information related to each slab. The labels must be recorded for future reference.

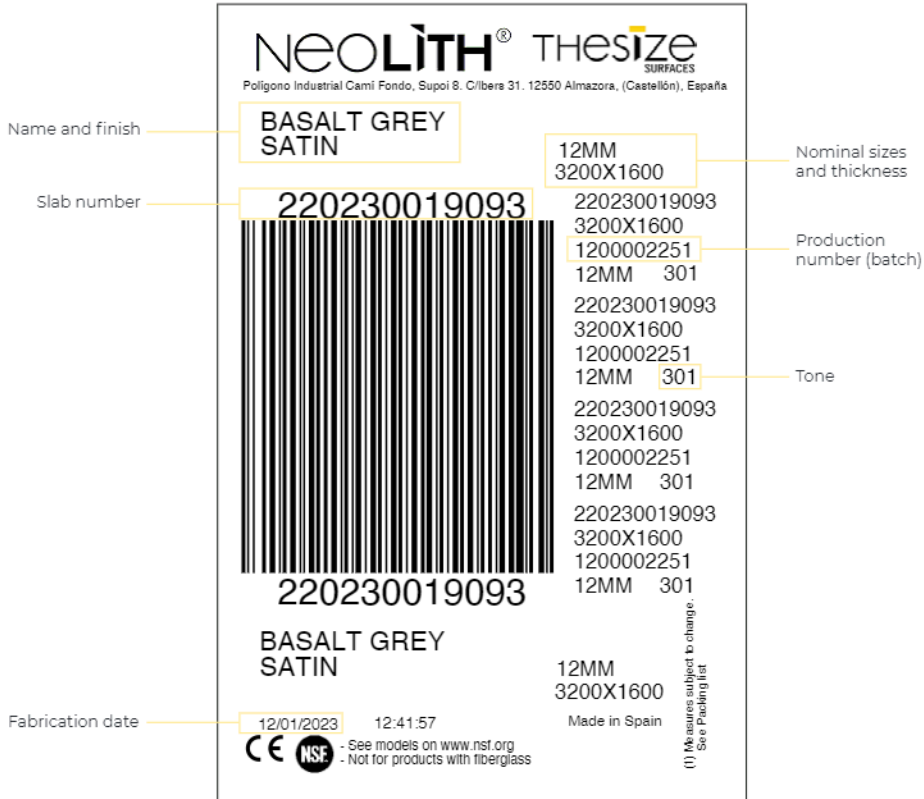

# 04 Cutting recommendations



# Pre-fabrication

Before cutting for production on a 12 mm or 20 mm slab, it is important to remove 2 cm off from each side of the slab to remove internal tension of the slab. The cutting order must follow the below sequence:  
 Check that the bench is straight, level and free of any debris. Check that there is enough support for the slab.

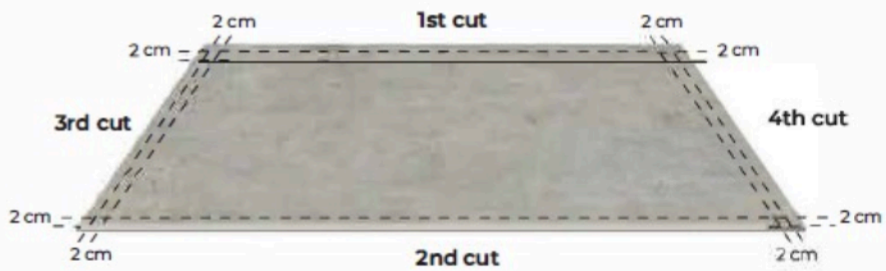

Incorrect

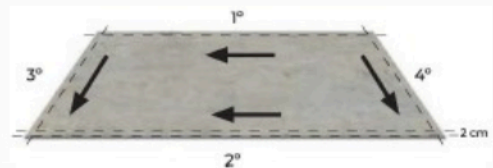
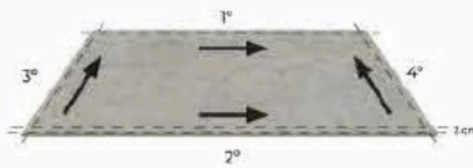

Correct

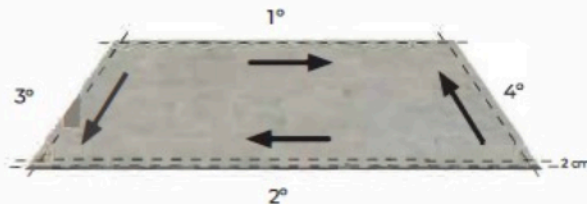

## 04/ Cutting recommendations

Before cutting a board for production, it is important to check the boards as the edges are not sanitized because the board is larger than the commercial area. It is convenient to trim the edges and remove the excess material so that it does not become part of the final product.

### 4.1 BRIDGE DISK OR SIMILAR

Prior to starting

Check that the bench is straight, level and free of any debris. Please ensure the bed is fully supporting the slab.

While cutting, it's important to use the maximum water flow to cool the disc. Be sure the water flow is aimed at the cutting area.

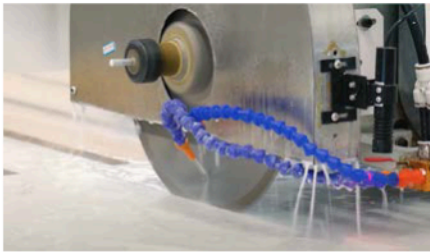

Correct



Incorrect

When cutting boards with a blade, it is important to reduce the speed by half at the beginning and at the end of the cut.

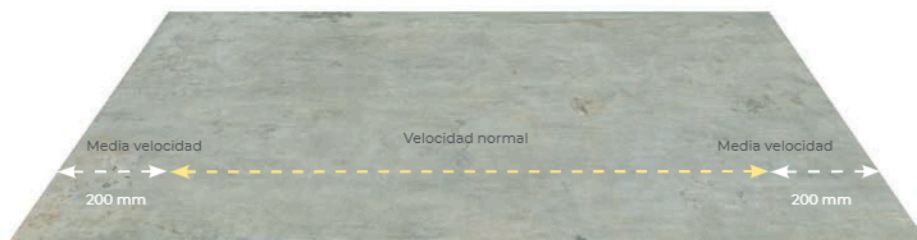

## CUTTING SEQUENCE:

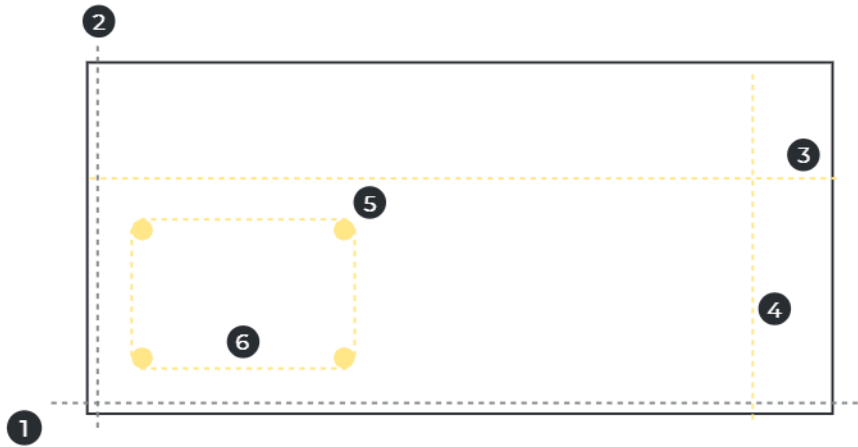

## Steps:

1. The first cut should be closest to the edge of the board on the long side and along the entire length of the board.
2. The second cut shall be perpendicular to the first cut and the closest to the edge. Also across the entire width of the board.
- 3 / 4. The following cuts will be made in order of length: from the longest to the shortest and cutting the whole board if possible.
5. To avoid any potential damage it's important to pre-drill inner corners when preparing cut-outs. All inner corners must have a minimum radius of at least 5 mm.
6. Proceed with the remaining cuts

## RECOMMENDATIONS:

Make sure the disc rotation coincides with the cutting direction.

Allow the blade to pass through the material at least 1.5mm to ensure a clean cut.



In the exceptional case that the disc is required to be lowered directly onto the slab, this should be done in automatic mode at the slowest possible speed.

Please check all machine and tooling condition prior to cutting.

Cutting 45° angles in Neolith requires a slower cutting speed. It also helps to use a piece of similar material at the start and finish of the cut to keep the disc aligned.

When using a new disc, do a few cuts so the disc segments can adapt and the diamonds open.

#### PARAMETERS FOR THE ULTRA-COMPACT NEOLITH DISC

THICKNESS	STRAIGHT CUT SPEED (M/MIN)	45° ANGLE SPEED (M/MIN)	Ø DISC (MM)	RPM	SURFACE SPEED (M/S)
6mm /6+	3,0	1,5	350	2300 - 2500	35 - 40
12 mm /12+	1,5	0,7	400	2000 - 2150	
20 mm	1,0	0,5			

Please refer to your blade manufacturer`s recommended cutting speed

#### No squared inner corner means:

No "L"-shaped countertop with 45° angled edges.

No squared cutout.

No inner 45° angled edge for the sink.

Absolutely NO 90° CORNER.

---

Bridge disc

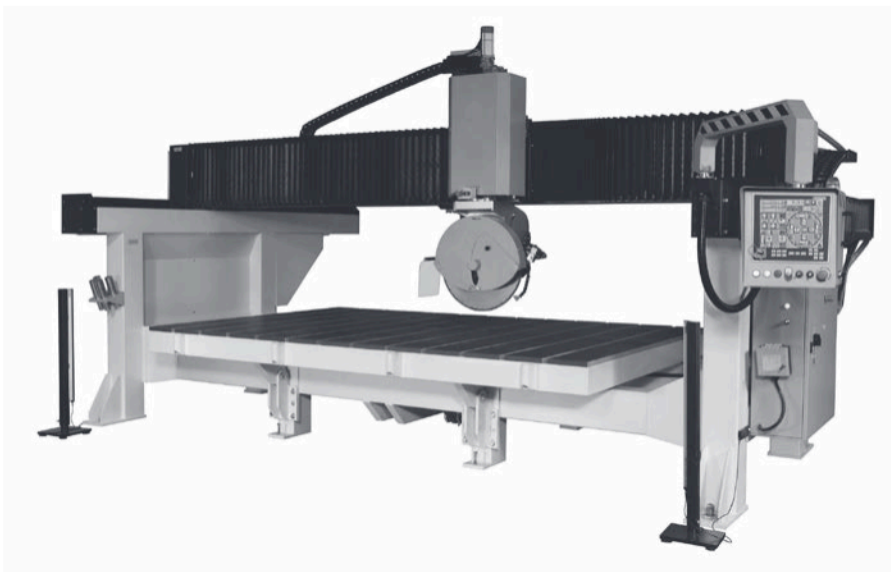

## 4.2 WATERJET

Before beginning:

No special entry speed needed when WJ cutting. PRESSURE (3.500 bars) RECOMMENDED.

Check that the bench is straight, level and free of any debris. Check that there is enough support for the slab.

CUTTING SEQUENCE:



Steps:

1. The first cut should be closest to the edge of the board on the long side and along the entire length of the board.
2. The second cut shall be perpendicular to the first cut and the closest to the edge. Also across the entire width of the board.
- 3/4. The following cuts will be made in order of length: from the longest to the shortest and cutting the whole board if possible.
5. To avoid any potential damage it's important to pre-drill inner corners when preparing cut-outs. All inner corners must have a minimum radius of at least 5 mm.

We recommend radiuses of more than 5 mm when the kitchen design allows as it will make the countertop firmer.

Lower pressure is recommended for drilling holes.

To begin the cutouts, firstly start at an internal point and then move closer to the cutting out position. The distance from the starting point to the cutting edge should be the minimum recommended (30 mm). Approach to the " AND "As you get closer to the cutting line, curve the cut to get a parallel approach, do not use a perpendicular approach as this could create a notch.



To do large cutouts or large parts, you must remember the following cutting sequence:

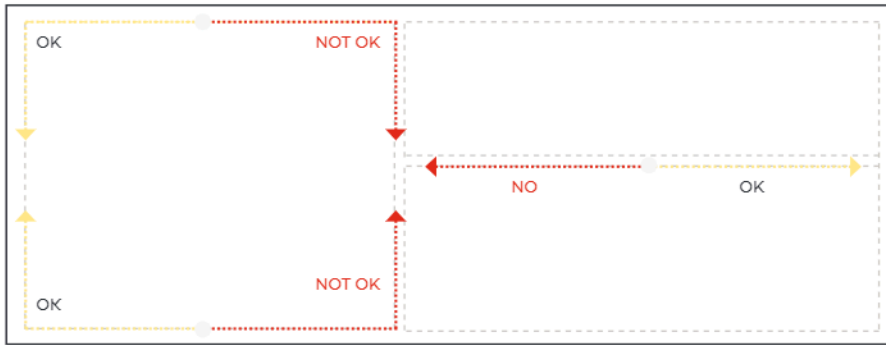

First cutting towards the edge of the slab from the hole or in parallel to the edge of the slab and following this direction to finish the part is recommended.

Making the first cut towards the center of the slab is not recommended.

### WATERJET PARAMETERS

THICKNESS	SPEED (M/MIN)	PRESSURE (BARS)	ABRASIVE FLOW RATE (KG/MIN)
6mm /6+	2	3500-3700	0,4
12 mm	1		
20 mm	0,7		

The values indicated are suggestions. The cutting speeds and abrasive flow rates can be adjusted for a cleaner finish.

### 4.3 CNC

Before starting:

Check that the bench is straight and level and that the suction cups are free of any debris. Check that there is enough support for the slab.

Make sure there are suction cups below the entire slab, especially below the part to be cut.

Avoid the use of mechanical anchors such as clamps or presses or similar.

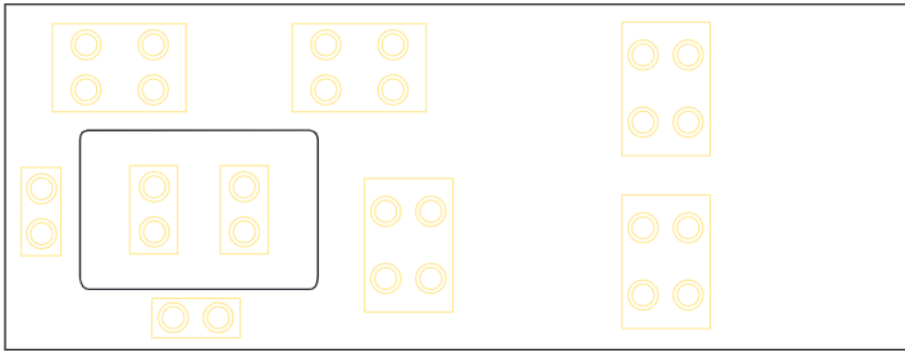

CUTTING SEQUENCE:

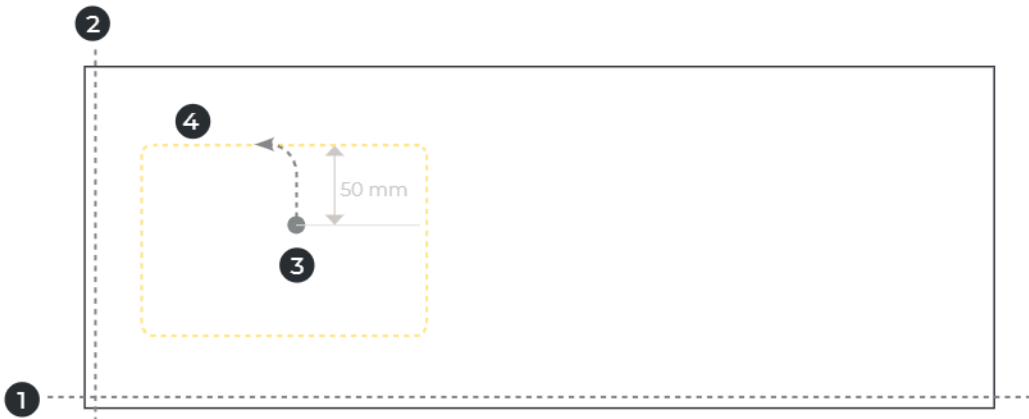

While working, apply plenty of water to cool the inside and outside of the tool.

**STEPS:**

1. The first cut should be closest to the edge of the board on the long side and along the entire length of the board.
2. The second cut shall be perpendicular to the first cut and the closest to the edge. Also across the entire width of the board.
3. Drilling with a crown bit.
4. Preparing the cutouts. All inner corners require a minimum bit of 5 mm.

We recommend bits larger than 5 mm when the kitchen design allows, as it will make the countertop firmer

First drill a hole inside the cutout, using the crown bit. Afterwards, use the router bit to get closer to the cutting line.

As you get closer to the cutting line, curve a bit; do not use a perpendicular approach as this could create a notch.

At the end of the cut, reduce the speed to 50% as you complete the cutout.

**TIPS FOR CUTTING WITH CNC TOOLS**

No special tool is needed to polish the edges. It can be done with the same tool as the rest of the materials.

**Crown drill bit:**

Drill the board with as little downward speed as possible, especially at the end of the drilling. Before finishing the drilling, raise the core bit a little to reduce the pressure inside.

**Cutting milling cutter:**

Do not use the oscillating option during the cut, as this could chip the board. Always start from a hole previously drilled with a core bit. Never lower the cutter bit directly onto the surface.

**Router bit:**

In the first two PASSES remove only 0.5 mm; then 2 mm per pass. It is not recommended to remove more than 6 mm on 12 mm boards or more than 10 mm on 20 mm boards.

**PARAMETERS FOR CNC TOOLS.**

TOOL		RPM	SPEED (MM/MIN)
Crown/Core/Drill bit		4500 – 5500	10
Cutting/Finger bit	12 mm	4500 – 5500	150
	20 mm	4500 – 5500	125
Milling/Incremental/Router bit		8000- 10000	250

# 05 Design and fabrication



# 05/ Design and fabrication

## 5.1 CUTOUT DESIGN GUIDELINES

The minimum distance between a cutout and the edge of the slab must be at least 5 cm.

Neolith recommends distances greater than 5 cm when the kitchen design allows as it makes the countertop stronger.

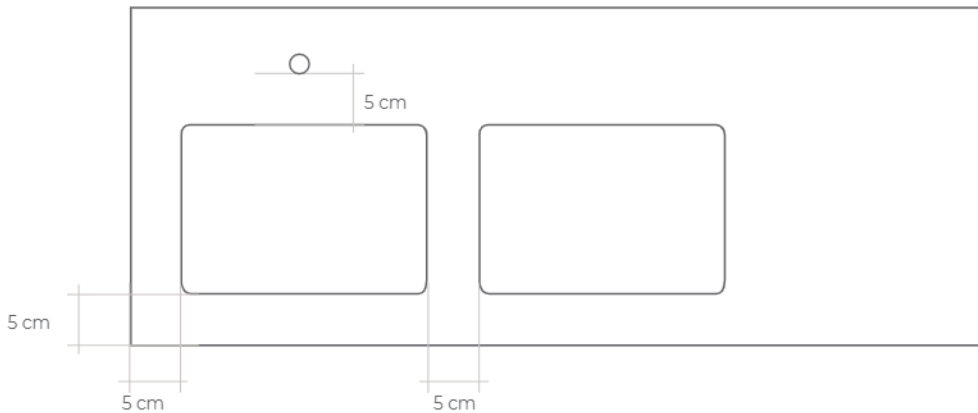

### IMPORTANT

All cutout corners must have a minimum radius of 5 mm. Never leave 90° angles. We recommend radiuses of more than 5 mm when the kitchen design allows as it will make the countertop firmer.



Correct



Incorrect



The correct way to create a cutout, except with waterjet and CNC, is to first drill the corners and then the rest of the cuts.

Guidelines for cutouts:

- Two straight cuts must never be joined.
- No squared inner corners.
- All inner corners must have a minimum radius of 5 mm.

The bottom and top edges of the cutouts are often a bit sharp or irregular; therefore BEVELLING them with diamond or abrasive sanders is recommended

Polishing the edges of the cutout is recommended to eliminate any micro-fissures created when cutting. The more intense this process is, the less risk there will be in the future.



Incorrect



Correct

If the countertop design so allows, avoid Neolith countertops with unbalanced weights:

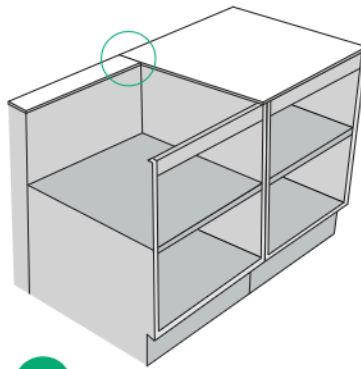
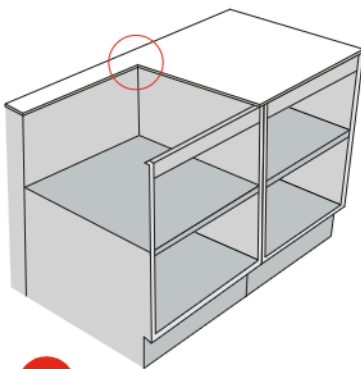

Incorrect



Correct

Irregular cuts are also not recommended such as for a "butler sink"; in these cases, add joints to the countertop design:



Correct

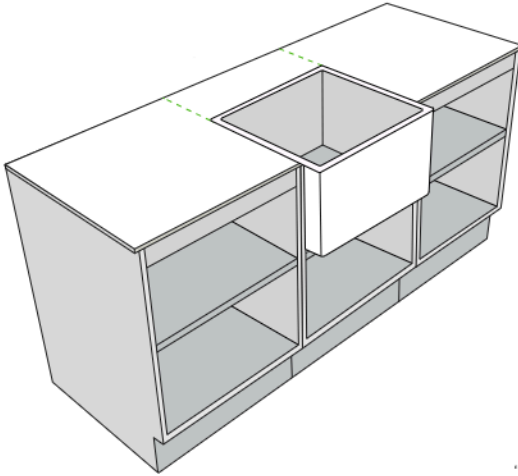

Other types of designs to be avoided:

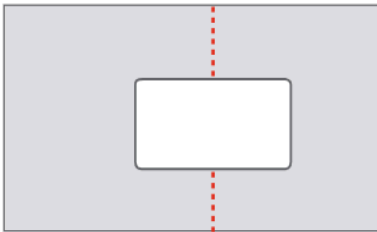

Incorrect

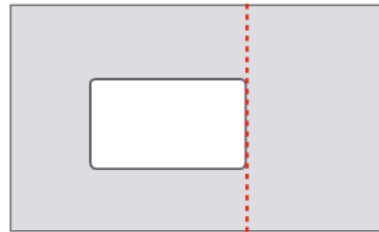

Incorrect

Sockets and switches:

Gaps made to insert accessories (sockets, switches, etc.) should be done using circular drills; they may overlap.



Correct

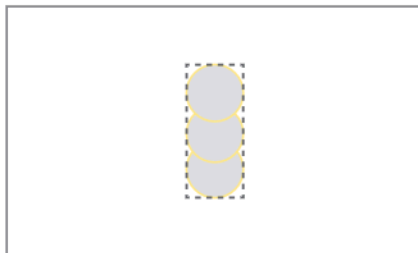

## 5.2 COUNTERTOP REINFORCEMENT



NEOLITH is not an structural material. It is important to ensure the substructure is strong enough to withstand all possible loads and stresses.

As a general rule, Neolith should be supported around the entire perimeter and at least every 60cm. If the distance between countertop supports is greater than 60cm, additional supports should be used. Every 60cm at the most, there should be transverse reinforcements.

### Countertops with 45° edges:

Reinforcements for 45° edges must be made with Neolith strips or dense granite; be careful when using other materials for reinforcement. The difference in the thermal expansion can cause the countertop to curve or the 45° edges may open over time.

NEVER USE QUARTZ REINFORCEMENT.

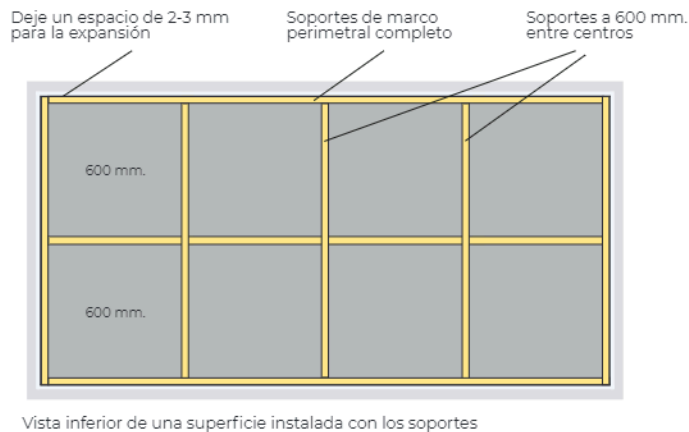

These reinforcements must be distributed under all mitred edges, sufficiently glued to both parts of it, and also assuring a full contact with the furniture. Please contact your glue supplier to choose a proper adhesive to ensure a strong bonding between the reinforcement and neolith slabs.

As a general rule, when using Neolith as reinforcement material, polyester glues are not recommended, otherwise acrylic and epoxy resin glues usually have better performance.

Please check Adhesive (7) section of this manual.

Moreover, it is important to reinforce the perimeter of the cutouts for greater strength and firmness in the area:



**NEVER USE ENGINEERED QUARTZ AS REINFORCEMENT FOR NEOLITH COUNTERTOPS**



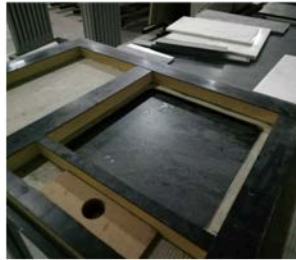

Reinforcements with expanded Polyurethane

Countertops with a straight edge:

For straight edge countertops, it must be ensured a full support of the whole countertop, properly levelled and avoiding gaps between furniture and the countertop

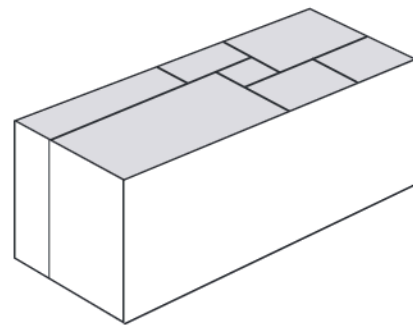

Countertops with 45° edges:

“The difference in the thermal expansion RATE can cause the countertop to BEND or the 45° JOINTS may open over time.”

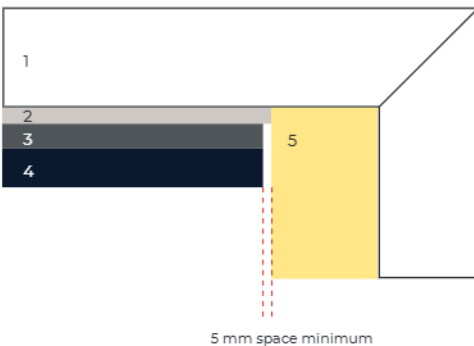

- 1 Neolith
- 2 Adhesive
- 3 Cabinets
- 4 Brick / stone / concrete base
- 5 Neolith or dense granite reinforcement

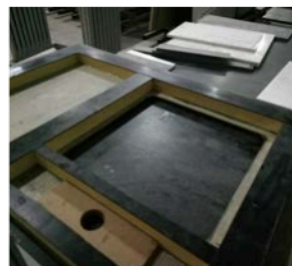
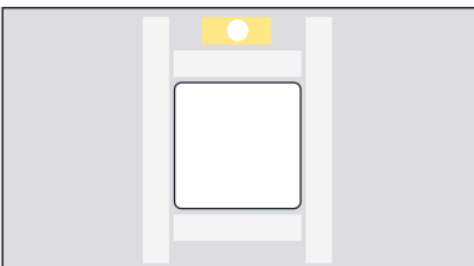

A reinforcement at the bottom, which does not restrict the movement of Neolith, is recommended (do not use quartz).

### 5.3 DRAINING RACKS

With a Neolith countertop, the only solution is creating sloped channels and combining them with an undermount sink.

The following considerations must be observed if drainer grooves are required:

- This part of the countertop will require additional cross-reinforcement with a solid top panel (18mm thick) or vertical rail (18mm x 45mm)
- The maximum depth of the channels is 3 mm for 12 mm thicknesses and 5 mm for 20 mm thicknesses.
- The minimum distance between channels should be 1 cm.
- NANOTOP by LITHOFIN or a similar product should be used to seal the grooves.

#### Manufacturing

##### Recess

Use a router bit and always begin at the sink gap. Never lower the router bit directly onto the surface.

The first two times, eliminate only 0.5 mm; then a maximum of 2 mm per pass.

##### Finish

Sand the grooves by hand to remove any marks made by the router bit. Use fine sandpaper until all marks have been removed.

Round the upper edges of the grooves and seal using NANOTOP by LITHOFIN or a similar product. In case a fully milled out draining board is required the entire area should be supported by a solid top panel

Please consider that with drainer grooves, the base colour of the material will be visible. In some cases, this will contrast with the colour of the surface.

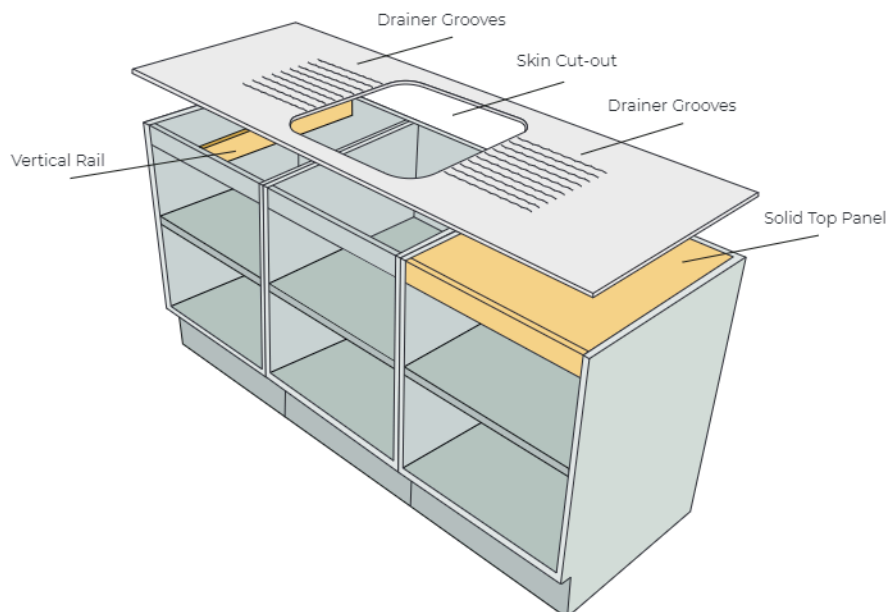

## 5.4 SINKS

### Flush sinks

Neolith only recommends the installation of flush sinks in 12 mm and 20 mm.

To perform the edge profile please check section no. 5.3 CNC

Removing more than 6 mm on a 12 mm slab or 10 mm on a 20 mm slab is not recommended.



### Undermount sinks

To reduce the risk of splintering to a minimum, a round edge with a radius of at least 2 mm is recommended.



For large-size sinks, place a rod support structure under the sink so the weight is on the rods and not the countertop.

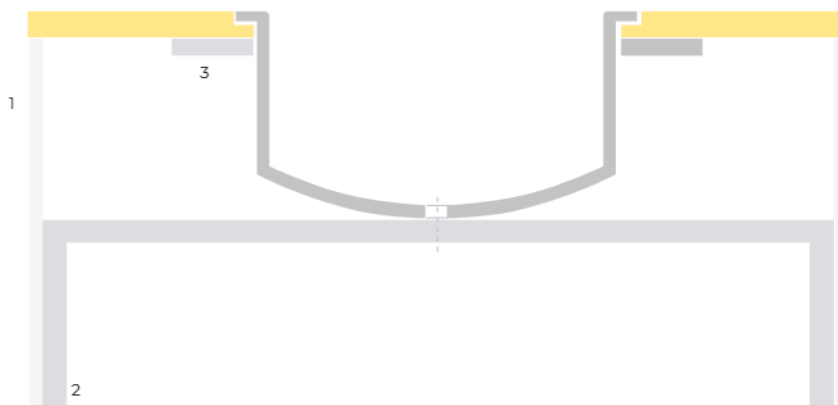

1. Furniture
2. Support rod
3. Reinforcement

Please check Adhesive (7) section of this manual

## 5.5 EDGES AND JOINTS

### Edges

Neolith recommends the following minimum edge profile details to ensure increased edge performance. It is the perfect compromise between esthetics and functionality. To perform the edge profile please check section no. 5.3 CNC

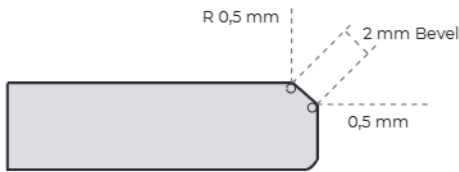

The edge is formed by a 2 mm bevel and by two rounded edges with a radius of 0.5 mm. The radius is barely visible but increases the edge impact resistance.

In high impact risk areas (sinks and dishwashers, for example), the edges could be as follows:

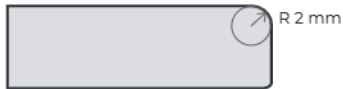

The greater the radius, the better it will bear any impacts. Please consider that the greater the bevel, the more base colour is exposed"

The edges can be wet or dry polished using standard granite or marble polishing tools.

Recommended edges for Neolith:

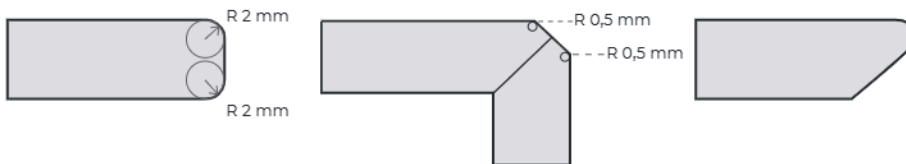

Round edge, R 2 mm

45° edge with a bevel, 2 mm

Reverse bevel/shark nose

### IMPORTANT



Neolith recommends treating polished edges with a water repellent sealant to further enhance edge performance.

45° edge with a bevel 12 or 20 mm



Round polished edge

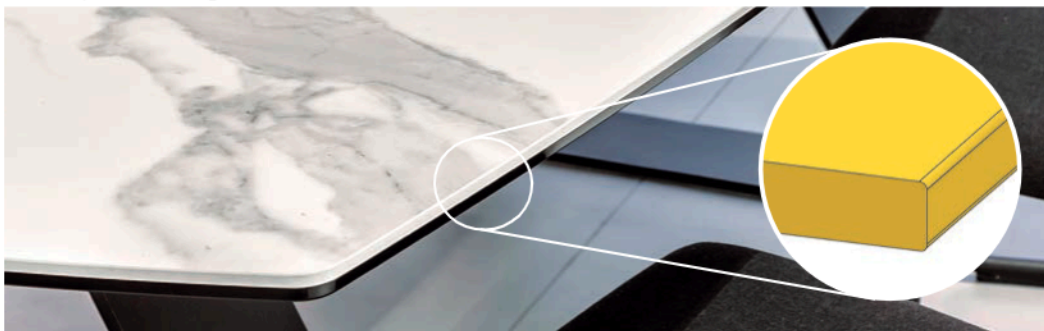

Reverse bevel/shark nose



## Types of Edges

Straight mitred joint

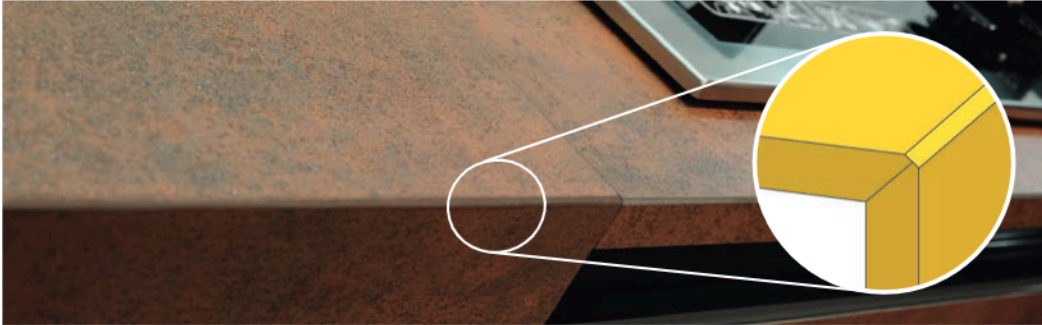

Overhang butt edge



Butt edge



## Joints

Given the texture of Neolith slabs, a micro-bevel for all joints is recommended. Even if the straight edges are perfect, they may be uneven due to the texture of Neolith slabs.



All joints must be sufficiently supported, either by an additional reinforcement underneath or support of the cabinetry. The support must run the full length of the joint.

Please check Adhesive (7) section of this manual

Please note that any alteration of the factory finished surface cannot be rectified.

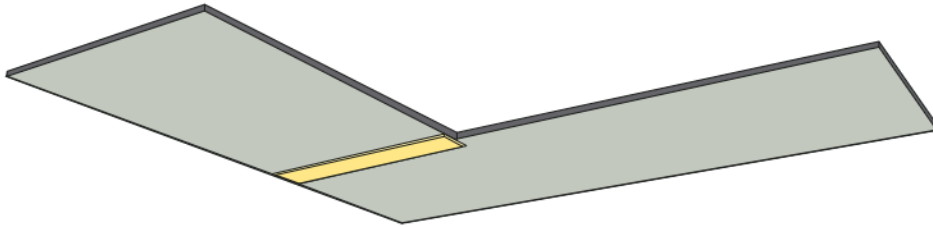

Additional support using a strip of Neolith underneath the joint

## 5.6 GLASS-CERAMIC / INDUCTION STOVETOPS

The minimum distance between the countertop and a stovetop must be 2 mm.

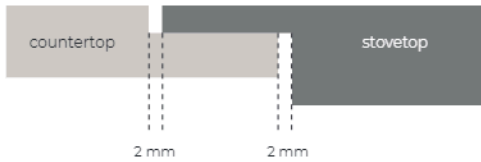

Use the right heat-resistant silicone or the gasket(s) supplied by the stovetop manufacturer.

Removing more than 6 mm on a 12 mm slab or 10 mm on a 20 mm slab is not recommended.

## 5.7 COUNTERTOP INSTALLATION

### Furniture:

Furniture must be in perfect condition and level before installing the countertop. Cabinets must be secured to each other and then secured to the wall.



### Backsplash:

The distance from the backsplash to the cooktop should be at least 5 cm if it is electric or induction. And of 8 cm if the stove is gas with flame. Make sure that the flame is never in direct contact with the backsplash.

### Legs or cascades:

The legs or cascades must have a structure that supports the weights. They should be glued to the structure only. It is recommended to leave a space of 3 mm to avoid the transmission of the movements of the floor to the countertop. This gap can be filled with rubber or foam strips that do not fix the legs to the floor. Never seal the leg to the floor.

### Expansion joints:

Given the irregularities found in walls and floors and possible structural movements in the building, leaving a 3 mm perimeter expansion gap between the countertop and walls is recommended. All gaps/joints should be sealed with a flexible sealant.

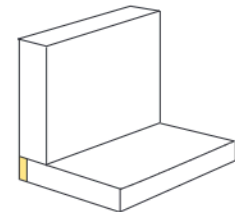

Please check Adhesive (7) section of this manual

The use of rigid adhesives such as "Liquid Nails" and epoxies is not recommended.

### 5.8 OVERHANG

Please consider the below recommendations regarding maximum dimensions of unsupported overhangs when designing countertops.

For high use and higher load areas, please reduce the maximum allowed dimensions for unsupported overhangs. Please contact Neolith technical department for assistance

#### 1. Full side overhang

##### A) Without cut-out

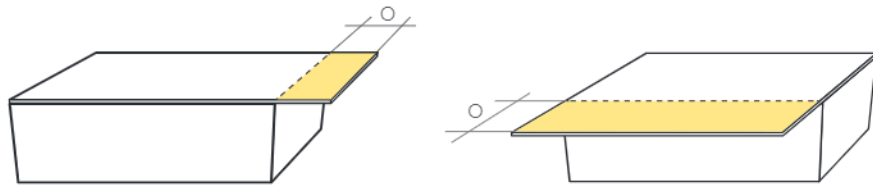

##### B) With cut-out

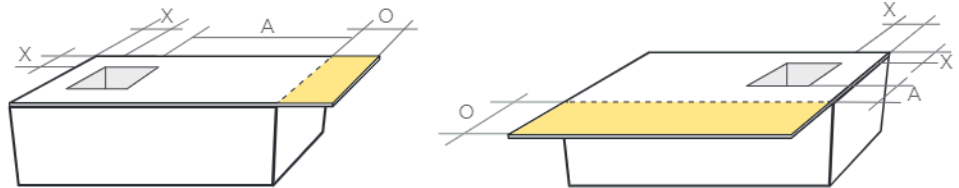

#### 2. Partial overhang

##### A) Without cut-out

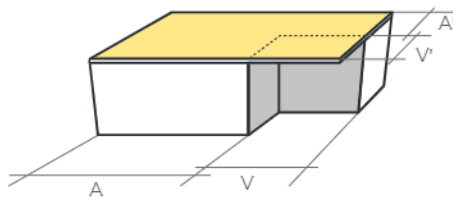

##### B) With cut-out

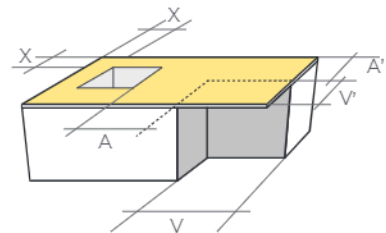

Please bear in mind that overhangs are not structural elements designed for high loads.

	THICKNESSES	
	12 mm	20 mm
O (Overhang)	≤ 350 mm (less than 350 mm)	≤ 500 mm (less than 500 mm)
V (Overhang)	≤ 500 mm (less than 500 mm)	≤ 1000 mm (less than 1000 mm)
V' (Overhang)	≤ 200 mm (less than 200 mm)	≤ 400 mm (less than 400 mm)
A (supports)	≥ O, ≥ V (greater than O, V)	≥ O, ≥ V (greater than O, V)
A' (supports)	≥ V' (greater than V')	≥ V' (greater than V')
X (measurement from the edge to the hole)	≥ 100 mm (greater than 100 mm)	≥ 100 mm (greater than 100 mm)

## 5.9 OUTDOOR COUNTERTOPS

Neolith recommends the use of exterior grade adhesives for outdoor applications/installations.

If there is no such substructure/support available, covering the top of the existing structure with reinforced cement panels is recommended.

When installing outside, avoid the use of wood or agglomerate planks due to their tendency to expand and contract as the weather changes.

Using flexible adhesives such as liquid nails, silicon or similar to secure an exterior Neolith countertop is not recommended.

Please check Adhesive (7) section of this manual



To glue the 45° angles, it is recommended to use an adhesive that is suitable for outdoor use and resistant to UV rays

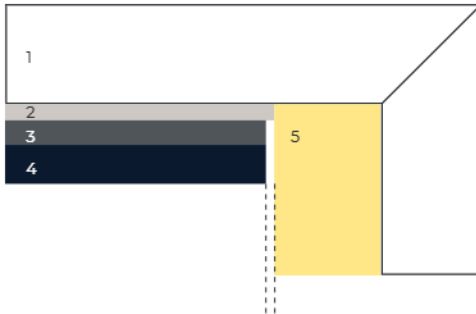

- 1 Neolith Slab.
- 2 Selected adhesive
- 3 Reinforced cement plank such as Kerdi-Board or similar.
- 4 Brick / stone / concrete base
- 5 Neolith or dense granite reinforcement

## HOW TO APPLY ADHESIVE

It is recommended to follow these steps to guarantee a proper adhesion between Neolith slabs and support material.



1. Spread the adhesive over the substrate using a minimum 10mm toothed trowel.
2. The toothed trowel that will be used to extend the adhesive on the back of the slab must have smaller teeth (square teeth of at least 3-4mm), in order to achieve a 100% adhesive surface coverage. Spread the adhesive on the back of the NeoLITH panels using a minimum 6mm toothed trowel.

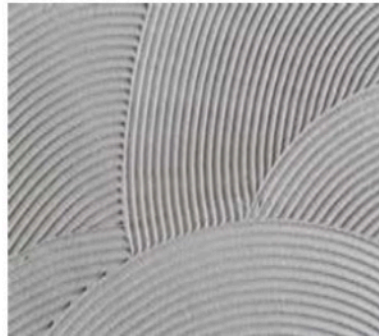

3. The adhesive must be applied in straight grooves, avoiding fan shapes, curved or similar patterns. The adhesive should be applied parallel to the shortest side of the slab to reduce the distance the air will travel to dissipate.

As a general rule, unless there is a very special need or condition, these are the adhesives to be used for glueing an outdoor countertop:

SUBSTRATE/STRUCTURE	ADHESIVE
BRICK/STONE	C2S2 (CEMENT GLUE)
METAL STRUCTURE	R2 (REACTIVE RESIN BASED ADHESIVE)
CEMENT FIBER BOARD	C2S2 (CEMENT GLUE)
WEDI/KERDI BOARD	R2 (REACTIVE RESIN BASED ADHESIVE)

## 5.10 L-SHAPED COUNTERTOPS

L-shaped countertops

Dividing L-shaped countertops into several parts is recommended to avoid 90° corners in one part.



L-shaped countertops made of a single piece without a 45° angle must have a minimum radius of 20mm. An increase in the size of the corner radius will improve the performance of the countertop and reduce the risk of failure"

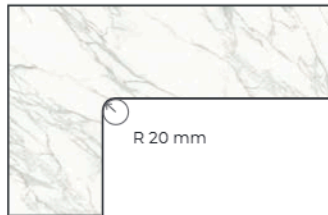

Make sure the furniture is in perfect condition and level before installing this type of countertop.

# 06 Heat



# 06/ Heat

Neolith parameters that are essentially relevant for all uses where heat is involved:

Maximum temperature increase: 10°C/min

Linear thermal expansion: between 5.3° and 6.7°. 10<sup>-6</sup> x°C<sup>-1</sup>

Sudden changes of temperature applied to Neolith should be avoided. To avoid sudden increases in temperature, use trivets under hot pots and pans after removing them from the burners.”

---

## 6.1 KITCHENS

When used as a kitchen worktop, Neolith has a good heat resistance for containers such as frying pans, pots, pans, coffee pots, etc. Electric appliances that give off heat, such as sandwich makers, can also be used. Even so, for utensils whose temperature is not controlled, it is advisable to use a trivet to avoid sudden changes in temperature.

---

## 6.2 BARBEQUES

If grills and/or barbeque grills are to be placed in a Neolith countertop, keep the following in mind:

- Always remember that all material expands when subjected to temperature changes (i.e. the metal structure of a barbecue grill) to prevent stress due to a lack of space for such expansion.
- Metal materials expand much more than Neolith; therefore, prevent direct contact by leaving a minimum space of 5mm (which could be increased depending on the dimensions of the barbeque grill, maximum temperature it may reach, etc.).
- Polishing the edges of the cutout is recommended to eliminate any micro-fissures created when cutting. The more intense this treatment is, the less risk there will be in the future.
- Inner corners must have minimum radiuses of 10 mm. We recommend diameters of more than 10 mm or producing the countertop in several parts, when the design so allows:

View of the top of the grill/barbecue grill built into a Neolith countertop.

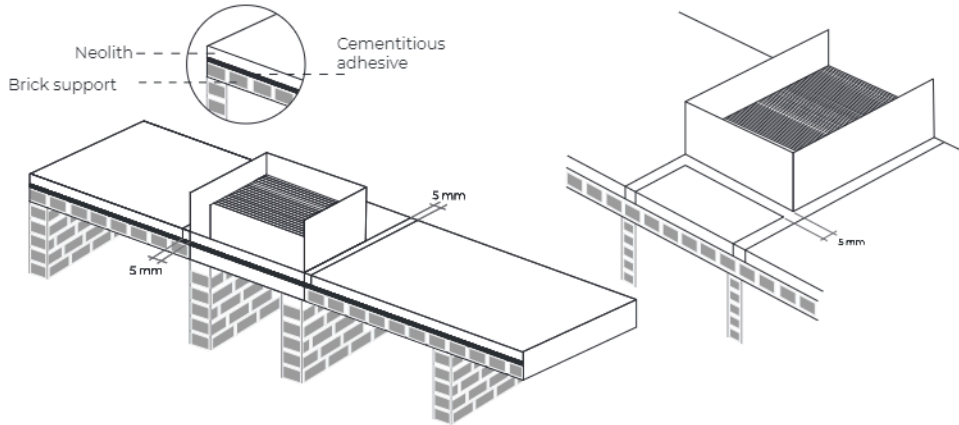

**WARNING**  
Neolith is not recommended for inner paneling for a fireplace.

### 6.3 FIREPLACES

Leaving a minimum space of 5 mm between the fireplace and Neolith and filling with thermal insulation such as fiberglass thermal insulation tape is recommended.

Possible uses for Neolith with built-in barbecue grills:



Possible uses for Neolith with fireplaces:



Front outer paneling: Front and side outer panelling: separated from the heat by an insulation/refractory layer (fire resistant).

Side outer paneling: separated from the heat by an inner refractory wall.

Countertop furniture



Ethanol fireplace design

Front outer paneling: separated from the heat by an inner refractory wall.

Side outer paneling: separated from the heat by an inner refractory wall.



fireplace shell      front - side paneling

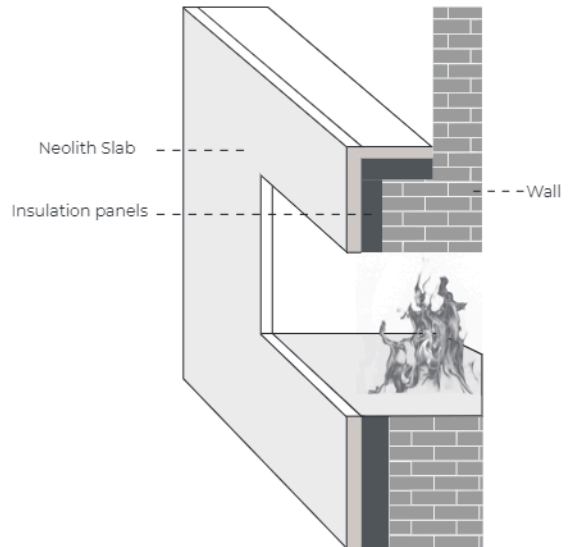

# 07 Glue



# 07/ Glue

An adhesive with chemical based bond characteristics is recommended. The use of polyester based adhesives is not recommended.

Acrylic and/or epoxy resin based adhesives for interior uses are recommended.  
For outdoor uses please check (6.9) section of this manual.

Always follow the adhesive manufacturers guidelines when using with Neolith.  
Ensure the adhesive is suitable for use with Neolith and also use the proper application technique(s).

## 7.1 JOINTS ADHESIVE

Reference the surface colour of the Neolith slab when preparing the glue for joints.

Before any adhesive application, the edges to be bonded must be clean and free of contamination.

To avoid adhesive failure, both slabs must be properly supported and movement of the parts prevented.

To correctly remove the excess adhesive before it fully hardens, please select the correct cleaning product for the type of adhesive used.

Please check joints (6.7) section of this manual

## 7.2 MITRED EDGES ADHESIVE

A round 2mm radius or a 45° 2mm bevel for mitred joints is recommended.

Please check edges design and production (6.5) and joints (6.7) sections of this manual. Always dry fit before gluing up.

Reference the base colour of the Neolith slab when preparing the glue for mitred joints.

Before applying the adhesive, the edges to be glued must be perfectly clean and dry. To avoid adhesive failure, the mitred joint must be sufficiently reinforced and movement of the parts prevented by using mitre clamps or similar tooling.

On decorpolished finish avoid applying excessive pressure on the parts.

To correctly remove the excess adhesive before it fully hardens, please select the correct cleaning product for the type of adhesive used.

## 7.3 BONDING TO CABINETRY / REINFORCEMENT

### INTERIOR USE

Before any adhesive application, the surface to be bonded must be perfectly clean and dry.

To avoid adhesive failure, 100% adhesive application to the surface in contact with the cabinetry/reinforcement is recommended.

Dot and dabbing technique must be avoided.

Please check reinforcement (6.2) and joints (6.7) sections of this manual.

For outdoor countertops, please also check outdoor (6.9) section of this manual.

---

## 7.4 SINKS ADHESIVE

Reference the sink surface colour of the Neolith slab when preparing the glue for joints.

Before any adhesive application, the both sink and slab surfaces to be bonded must be perfectly clean and dry and free of contamination..

To avoid adhesive failure, both sink and slab must be properly supported and movement of the parts prevented.

To correctly remove the excess adhesive before it fully hardens, please select the correct cleaning product for the type of adhesive used.

Please check sinks (6.4) section of this manual

---

## 7.5 WATERFALL LEGS ADHESIVE

A round 2mm radius or a 45° 2mm bevel for mitred joints is recommended.

Please check edges design and production (6.5) and joints (6.7) sections of this manual.

Always dry fit before gluing up.

Reference the base colour of the Neolith slab when preparing the glue for mitred joints.

Before any adhesive application, the surfaces to be bonded must be perfectly clean and dry free of contamination..

To avoid adhesive failure, the mitred joint must be sufficiently reinforced and movement of the parts prevented by using mitre clamps or similar tooling.

On decorpolished finish avoid applying excessive pressure on the parts.

To avoid adhesive failure, 100% adhesive application between the waterfall leg and the cabinetry with flexible adhesive is recommended. Dot and dabbing technique must be avoided.

To correctly remove the excess adhesive before it fully hardens, please select the correct cleaning product for the type of adhesive used.

To allow for expansion on vertical panels or waterfall legs, a 3mm space between the vertical panel/ waterfall leg and floor is recommended. This space should be sealed with flexible sealant.

# 08 Protective edges & profiles



## 08/ Protective edges & profiles

### 8.1 WORK AREAS SUBJECT TO HARSH CONDITIONS

Even though a Neolith® countertop is resistant to impacts, there are harsh work atmospheres in which the edges recommended in section 6.5 of our countertop technical manual are not enough to properly protect the countertop in these environments.

In these areas with a **high risk of impact**, behind a restaurant bar counter, for example, rounded edges should be considered for the countertop.

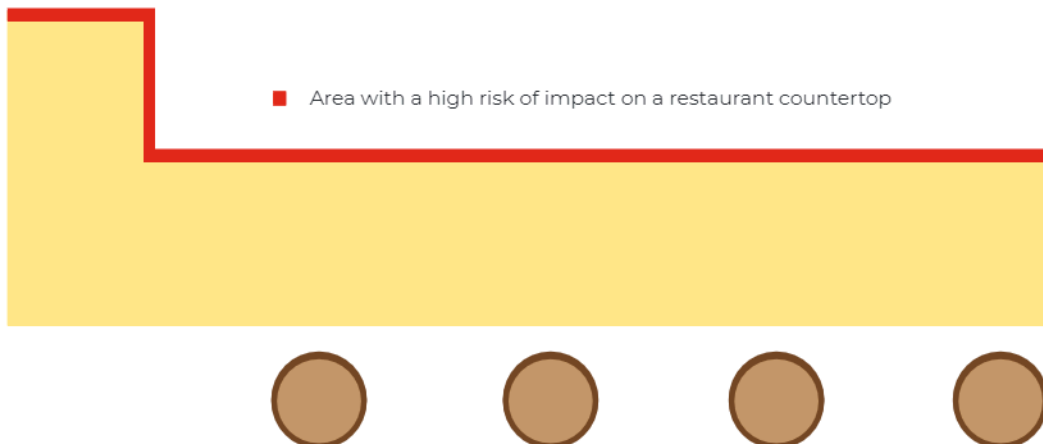

Due to the design of some models, this option may not be the most aesthetic measure.

To solve this problem, Neolith sought the assistance of Schlüter®-Systems, whose construction systems are the result of extensive experience in the sector and guarantee a good final finish.

Schlüter®-Systems produces several profiles that are suitable for protecting Neolith countertop edges.

Below is a summary of some profiles that have led to the best results with the various Neolith® models and thicknesses.

The profiles can be secured to the countertop with industrial silicone like SoudalT-Rex. The joint between the profile and the Neolith® countertop was rejointed with Akemi Composil colored silicones.

Profiles combined with a substrate like Schlüter®-Kerdi-Board or similar.

Sometimes, substrates like Schlüter®-Kerdi-Board are used.

Schlüter®-Kerdi-Board is an extruded rigid foam panel covered on both sides with special reinforcement material to guarantee the effectiveness of the adhesive. Schlüter®-Systems has developed various types of profiles to cover the visible edge of the substrate.



1. Neolith® Beton 12 mm with Schlüter®-Rondec-Step and its outer angle

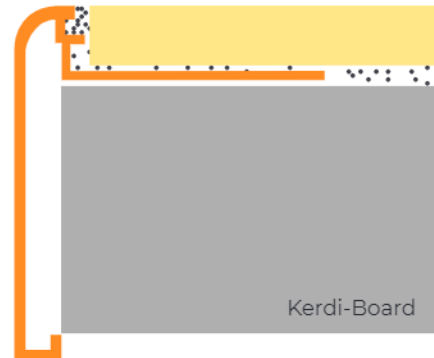

Cross-sectional image of a Schlüter®-Rondec-Step profile



## PROJECTS WITH PROFILES

Restaurant Miramar - Llançà, Girona, España



Restaurant Enigma - Barcelona, España

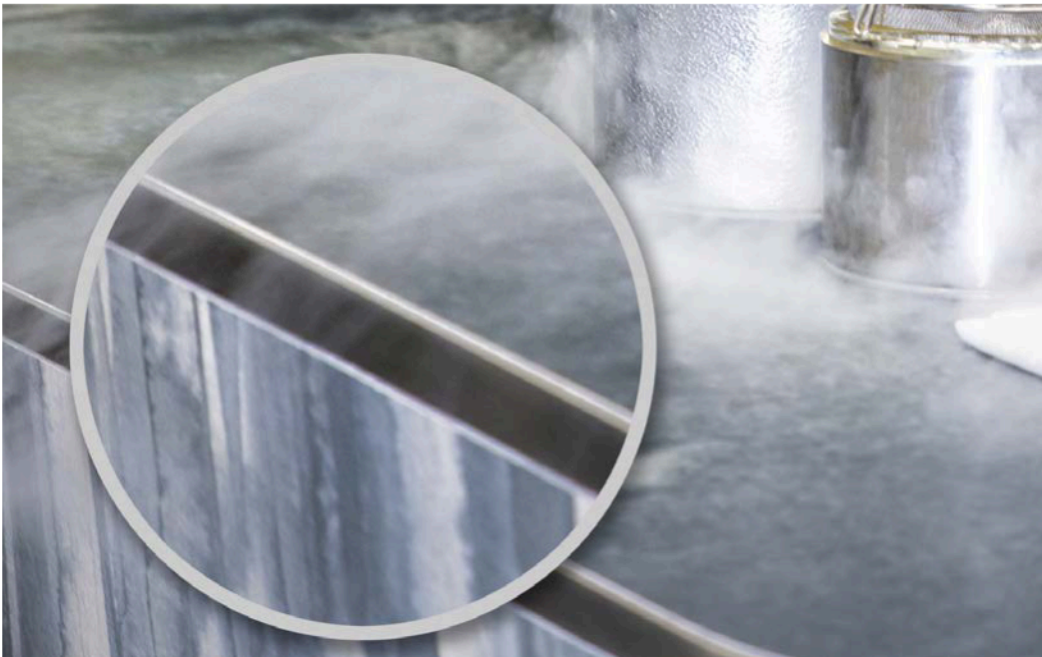

Restaurant Confusion - Porto Cervo, Italia



Restaurant Kutchiin & Campus Loft - Münster, Alemania



Gasma, Gastronomic University - Castellón, España





Prepared by:	Reviewed by:	Approved by:
Ángela Cortés	Alejandra Tena	Lucas Martínez

**APPROVAL AND CONTROL MODIFICATIONS**

REVIEW	DATE	REASON FOR MODIFICATION	AFFECTED PAGES	APPROVAL RESPONSIBLE
00	may-24	Document creation	ALL	Quality Resp.
01	sep-24	Corrections	ALL	Quality Resp.

**RELATED DOCUMENT**

Document	Code	Document Type	Process



NEOLITH

[www.neolith.com](http://www.neolith.com)